

Finishes Hot Dipped Galvanized

Materials Carbon Steel, Stainless Steel 304SS & 316SS

Recommended Designed to support pipe flange horizontally. The straight cut pipe thread on nipple provides up to 4 1/2" of vertical adjustability

Notes Support requires 2" schedule 40 extension pipe (not supplied) to be cut in the field.

For a class 125 flange only.

Gussets added on sizes 6" and up.

Stainless Steel Only Available for sizes 4" - 8"

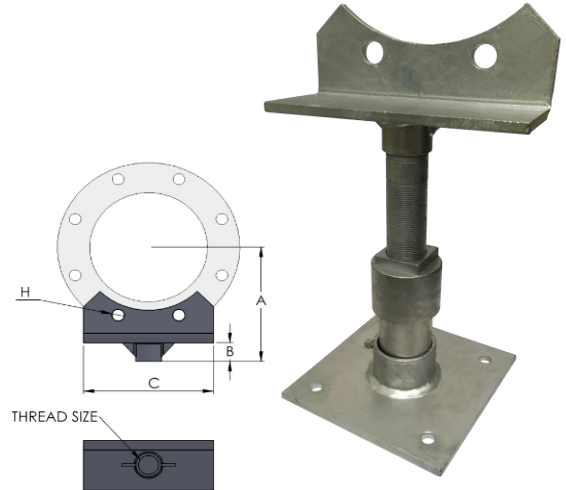

SIZE	SADDLE SPECIFICATION DATA				
	A	B	C	H	THREAD SIZE
3	6 1/2	1 1/2	6 1/2	13/16	1 1/4 - 7
4	6 7/8	1 1/2	6	13/16	1 1/4 - 7
6	7 7/8	1 1/2	8	15/16	1 1/4 - 7
8	9 1/8	1 1/2	9 1/8	15/16	1 1/4 - 7
10	10 5/16	1 1/2	8	1 1/16	1 1/4 - 7
12	11 13/16	1 1/2	9 1/2	1 1/16	1 1/4 - 7

QWI 4.3.1 Issue Date May/22 Rev.2

KIT SPECIFICATION DATA

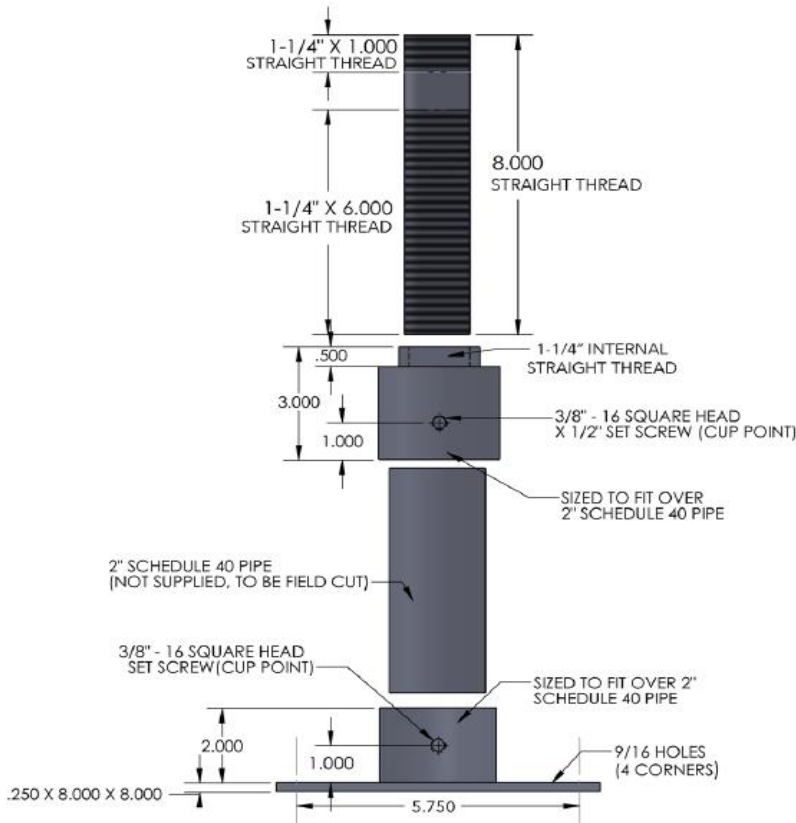

Note: when referencing a printed copy of this specification page, please insure it is the latest version as found on our website at www.taylorpipesupports.ca