

**Finishes** Hot Dipped Galvanized, except for Stainless Steel Screws

**Materials** Carbon steel assembly with stainless steel set screws.  
Stainless Steel 316SS 3" up to 12"

**Approvals** Complies with MSS SP-58 and SP-69 (Type 37, 38).

**Recommended** Designed to support pipe horizontally. Straight cut pipe thread on nipple provides up to 4 1/2" of vertical adjustability.

**Notes** Saddles accommodate ductile iron pipe and IPS.  
Support requires 2" Schedule 40 (for 2" - 12") or 3" Schedule 40 (for 14" - 16") extension pipe to be cut in the field.

\*\*Factory tested 11,000 lbs (for the saddle portion)\*\*

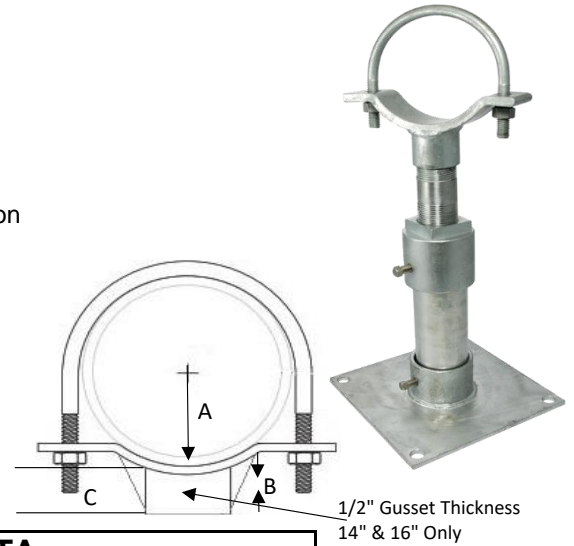

IPS or Ductile Iron Pipe Size	SPECIFICATION DATA			
	A	B	C	THREAD SIZE
2	1.500"	1 1/2	1/2-13	1 1/4 - 7
3	2.030"	1 1/2	1/2-13	1 1/4 - 7
4	2.450"	1 1/2	1/2-13	1 1/4 - 7
6	3.500"	1 1/2	5/8-11	1 1/4 - 7
8	4.580"	1 1/2	5/8-11	1 1/4 - 7
10	5.600"	1 1/2	5/8-11	1 1/4 - 7
12	6.650"	1 1/2	5/8-11	1 1/4 - 7
14	7.750"	3	7/8-9	2 1/2 - 4
16	8.800"	3	7/8-9	2 1/2 - 4

**PIPE SIZES 2 - 12**

**PIPE SIZES 14 - 16**

