

# #525 Pipe Saddle Support C/W U-Bolt

**Finish** Bare Metal, Hot Dipped Galvanized

**Material** Carbon Steel, Stainless 304SS & 316SS

**Approvals** Complies with Manufacturers' Standardization Society MSS SP-58 and SP-69 (Type 36, 37)



**Recommended** 3" through 36"

Designed to be used in conjunction with a base stand to support pipe running close to the floor. U-Bolt secures pipe to saddle. Specify pipe size, figure number, name and finish.

Base stand ordered separately. Requires accurate center line of pipe to floor dimension "L".

Welded Gussets on 8" and up

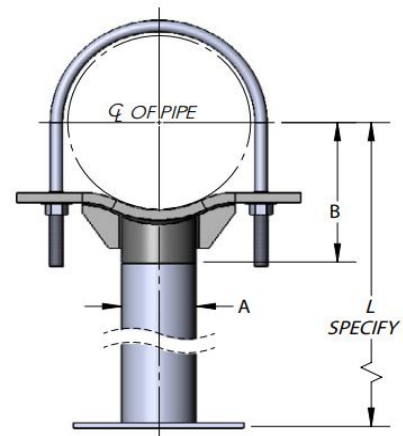

PIPE SIZE	SPECIFICATION DATA		WGT. EACH (LBS.)
	PIPE SIZE A	B	
3	3	3 3/4	6.00
4	3	4 3/16	6.72
5	3	4 13/16	7.30
6	3	5 7/16	11.06
8	3	6 15/16	14.30
10	3	8 7/16	18.53
12	3	9 15/16	23.92
14	4	10 15/16	39.10
16	4	12 3/8	44.47
18	4	13 7/8	52.95
20	6	15 3/8	84.72
24	6	17 15/16	100.00
30	6	21 5/16	113.10
36	8	24 1/2	163.74

QWI 4.3.1 Issue Date Dec/23 Rev.8