

# #24F Clevis Hanger Flat Top

**Finishes** Zinc Plated, Bare Metal, Hot Dipped Galvanized

**Materials** Carbon Steel, Stainless Steel 304SS & 316SS

**Approvals** Complies with MSS SP-58 and SP-69 (Type 1).

**Recommended** Recommended for the suspension of non-insulated stationary pipe where space is limited.



UPPER LOCKNUT MUST BE TIGHTENED SECURELY TO ASSURE PROPER HANGER PERFORMANCE

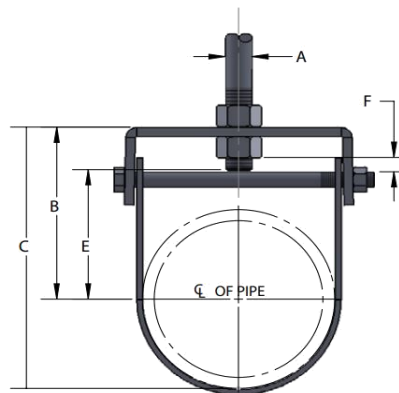

IRON PIPE SIZE	SPECIFICATION DATA						APP'X WT. EACH (LBS)	REC. MAX LOAD (LBS.)
	BOLT	A	B	C	E	F		
1 1/2	1/4	3/8	2 1/8	3 1/8	1 5/16	5/16	0.42	250
2	1/4	3/8	2 1/2	3 11/16	1 5/8	7/16	0.46	300
2 1/2	5/16	1/2	2 7/8	4 3/16	1 7/8	7/16	0.78	500
3	5/16	1/2	3 5/8	5 3/8	2 9/16	1 1/16	0.98	500
3 1/2	5/16	1/2	4 1/16	6 1/16	2 15/16	3/4	1.36	500
4	3/8	5/8	4 1/16	6 5/16	2 11/16	3/16	1.38	700
5	1/2	5/8	4 7/8	7 5/8	3 1/2	5/8	2.08	700
6	1/2	3/4	5 1/2	8 7/8	3 7/8	7/16	2.82	900
8	5/8	3/4	6 3/8	10 7/8	4 5/8	5/16	4.34	1000
10	3/4	7/8	8 5/8	14	6 7/8	1 1/2	8.06	1800
12	3/4	7/8	9 5/8	16	7 5/8	2 9/16	18.05	1800

QWI 4.3.1 Issue Date Apr/22 Rev.0

Note: when referencing a printed copy of this specification page, please insure it is the latest version as found on our website at [www.taylorwalraven.ca](http://www.taylorwalraven.ca)

For more information, please contact Customer Service at 1-800-263-8652