

# #114 Turnbuckle Adjuster

- Finishes** Bare Metal, Copper Plated
- Materials** Malleable Iron
- Approvals** Complies with MSS SP-58 and SP-69 (Type 15)
- Recommended** Designed to provide vertical rod adjustment with split ring hanger.

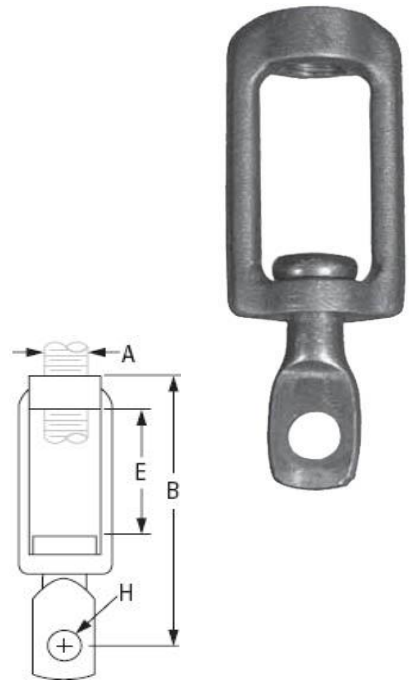

ROD SIZE A	PIPE SIZE	SPECIFICATION DATA			MAX. REC. LOAD (Lbs.)	WEIGHT EACH (LBS)
		B	E	H		
3/8-16	1/2 - 2	4.300	2	0.410	730	0.30
1/2-13	2 1/2 - 3 1/2	4.300	2	0.410	730	0.28

QWI 4.3.1 Issue Date Nov/21 Rev.3